

Jan 5-1934
Geo. B. Hamer

"ASSESSOR'S PLAT OF WM.F. ARNOLD ADDITION" TO THE CITY OF THREE RIVERS ST. JOSEPH CO. MICHIGAN

BEING A RESURVEY OF LANDS FORMERLY KNOWN AS WM. F. ARNOLD ADDITION TO THE VILLAGE OF LOCKPORT

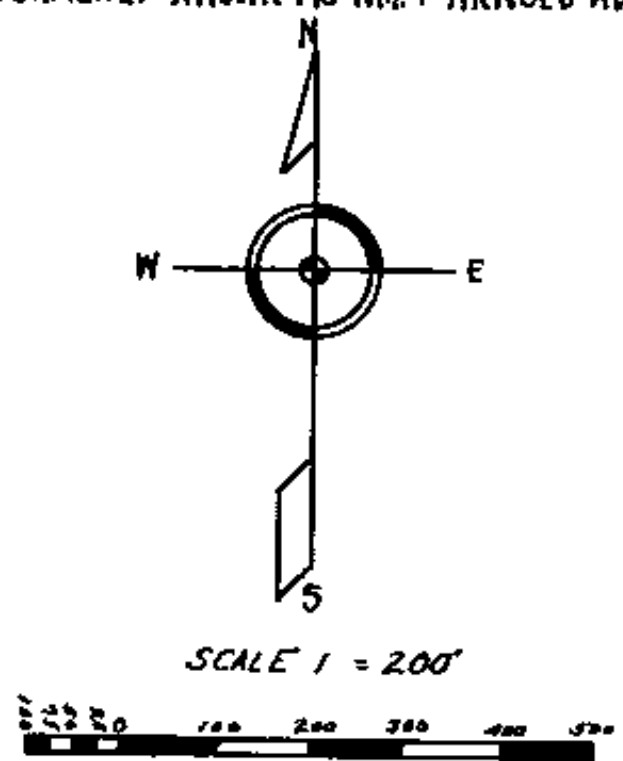
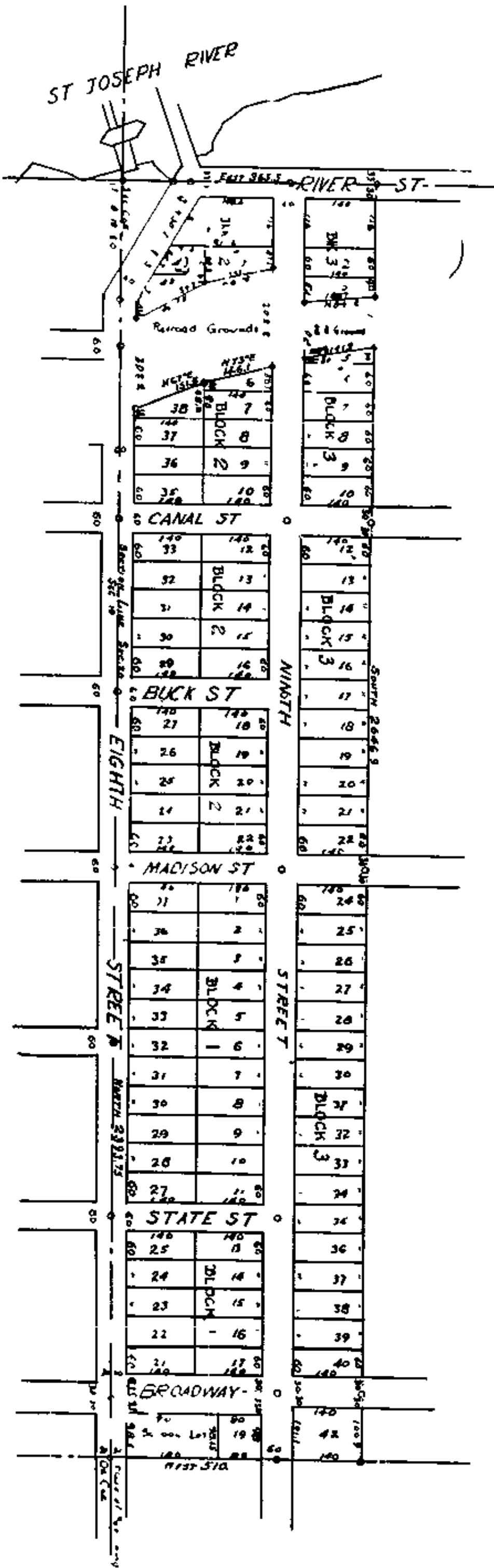

DESCRIPTION

The land embraced in this Assessor's Plat of Wm F Arnold Addition to the City of Three Rivers, St Joseph Co Michigan is a part of the West one half of the West one half of the North West one fourth of Section 20 T6 SR11W described as follows Beginning at the Quarter Section corner between sections nineteen and twenty running along section line 2337.5 feet thence north thirtydegrees east 291.3 feet to intersection with section line between sections seventeen and twenty, thence east 365.5 feet along section line, thence south 2646.9 feet to quarter section line thence west 510 feet to place of beginning

ASSESSOR'S CERTIFICATE

Whereas it has been deemed advisable and necessary by the vote of the commissioners of the city of Three Rivers to have the land known as Wm F Arnold Addition to the Village of Lockport, resurveyed and according to Sections 330 and 335, Compiled Laws of 1915 as amended by Act No 360 Public Acts of 1925

I hereby certify that I have caused same to be done and that the annexed map is the land generally known as **WM. F. ARNOLD ADDITION TO THE VILLAGE OF LOCKPORT** and that all streets as shown on this plat have been duly acquired by the public for street purposes by reason of purchase, dedication condemnation or adverse possession and that all streets shown are now open as streets and are being used by the public

Signed and Sealed Ota D. Avery
in presence of George J. ...
...

STATE OF MICHIGAN }
County of St Joseph }
On this 5th day of Sept 1933

before me in and for said county personally came the above named Ota D Avery Assessor for the City of Three Rivers known to me to be the person who executed the above and acknowledged the same to be his free act and deed.

My Commission Expires Sept 1-1934

SURVEYOR'S CERTIFICATE

I hereby certify that the plat hereon delineated is a correct one and that permanent metal monuments of not less than one inch (1) in diameter and fifteen inches (15") in length set in a concrete base at least four inches (4) in diameter and forty eight inches (48) in depth have been placed at all points marked thus "o" as thereon shown at all angles in the boundaries of the land platted, at all intersections of the streets with the boundaries and with each other

All measurements are in feet and decimals thereof thus 172.7'

Geo. B. Hamer
REGISTERED SURVEYOR
CERTIFICATE OF MUNICIPAL APPROVAL

This plat was approved by the city commission of Three Rivers at a meeting held Sept 11 1933
Clerk

CERTIFICATE OF COUNTY BOARD

This plat was approved on the 12th day of September 1933
Edward J. ...
County Treasurer

REGISTER'S OFFICE
STATE OF MICHIGAN
Received in Record
Date of Sept 11 1933
in Vol ...
on Page ...